

149 SERIES CENTRIFUGAL PUMPS

The centrifugal pump is a close-coupled pump with Phenolic, Noryl®, Aluminum wetted parts; and Ceramic vs. Carbon face, or Silicone Carbide mechanical seal; for pumping corrosive fluids. Face seal components are constructed from 304 Stainless Steel metal parts and Nitrile or EPDM elastomers.

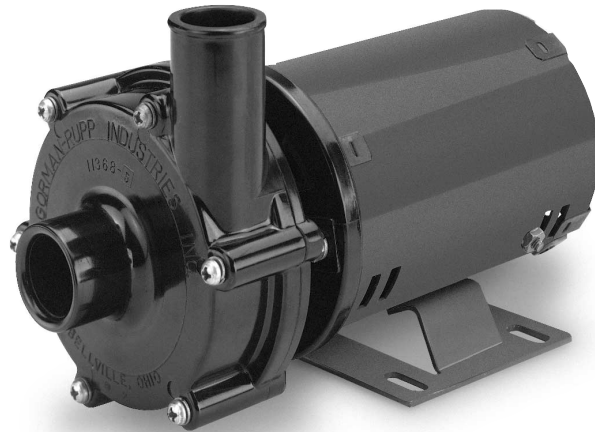

TROUBLESHOOTING GUIDE

The troubleshooting guide is a suggestion or aid in helping solve problems that might arise.

NOTE: Never work on pump without making certain power is off.

UNIT WILL NOT PUMP

1. No liquid in pump (requires flooded suction). Do not run dry.
2. Closed valves or blocked lines.
3. Air lock in suction or discharge lines.
4. Leaking shaft seal.

LOW FLOW

1. Air leak in suction line.
2. Closed valves or blocked lines.
3. Dirty filter systems.
4. Reverse rotation (on 3-phase or dual voltage, reversible motors).
5. Low voltage.
6. Leaking shaft seal.

MOTOR DOES NOT TURN

1. No power to motor. Check that all power switches are on. Be sure fuse or circuit

breaker is properly set. Timers or controls properly set. Check motor wiring at terminals or plug.

MOTOR RUNS HOT

These motors will run "hot" to the touch. However, this is normal. Thermal overload protector will function to turn them off if there is an overload or high temperature problem. Excessive heat can be caused by:

1. Low voltage or incorrect voltage.
2. Installed in direct sun.
3. Poor ventilation.

MOTOR THERMAL PROTECTOR OPENS ELECTRIC CIRCUIT

1. Motor is improperly connected.
2. Low voltage due to under-sized wire or low incoming voltage.
3. Incorrect voltage.
4. Overload due to binding in pump or bad motor bearings.

NOISY OPERATION OF MOTOR

1. Worn bearings.
2. Damaged cooling fan.

NOISY OPERATION OF PUMP

1. Air leak in suction line. Bubbles in liquid returning to pump inlet.
2. Restricted suction line due to blockage or under-sized pipe.
3. Cavitation (refer to 1 & 2 above).
4. Foreign matter in pump impeller.

LEAKS

1. Loose hose clamps.
2. Leaking gasket. (Tighten screws to approx. 15-20 in.-lbs.).
3. Damaged or broken pump parts.
4. Leaking shaft seal.

WARRANTY

Gorman-Rupp Industries warrants to Buyer that products sold by it will upon shipment conform to the description on the face hereof and any written specifications expressly approved by Seller and be free from defects in title, material and workmanship. NO OTHER WARRANTY, WHETHER EXPRESS OR IMPLIED, INCLUDING ANY WARRANTY OF MERCHANTABILITY OR FITNESS FOR A PARTICULAR PURPOSE, SHALL EXIST IN CONNECTION WITH ANY PRODUCTS SOLD BY SELLER, AND ALL SUCH WARRANTIES ARE HEREBY EXPRESSLY EXCLUDED.

WARNING

DANGER:

Improper application, installation, adjusting, or servicing can result in serious injury or death. Always disconnect power source before working on these products.

Caution:

Products with electric motors must be properly grounded and may start automatically at any time. For product information, consult Gorman-Rupp Industries, Bellville, Ohio 44813, Phone (419) 886-3001.

EXPLODED VIEW – 149 SERIES CENTRIFUGAL PUMPS

REPLACEMENT KITS

REF. NO.	DESCRIPTION	PART NO.
1	Body Kit	02501-244
2	Impeller & Seal Kit	02501-245

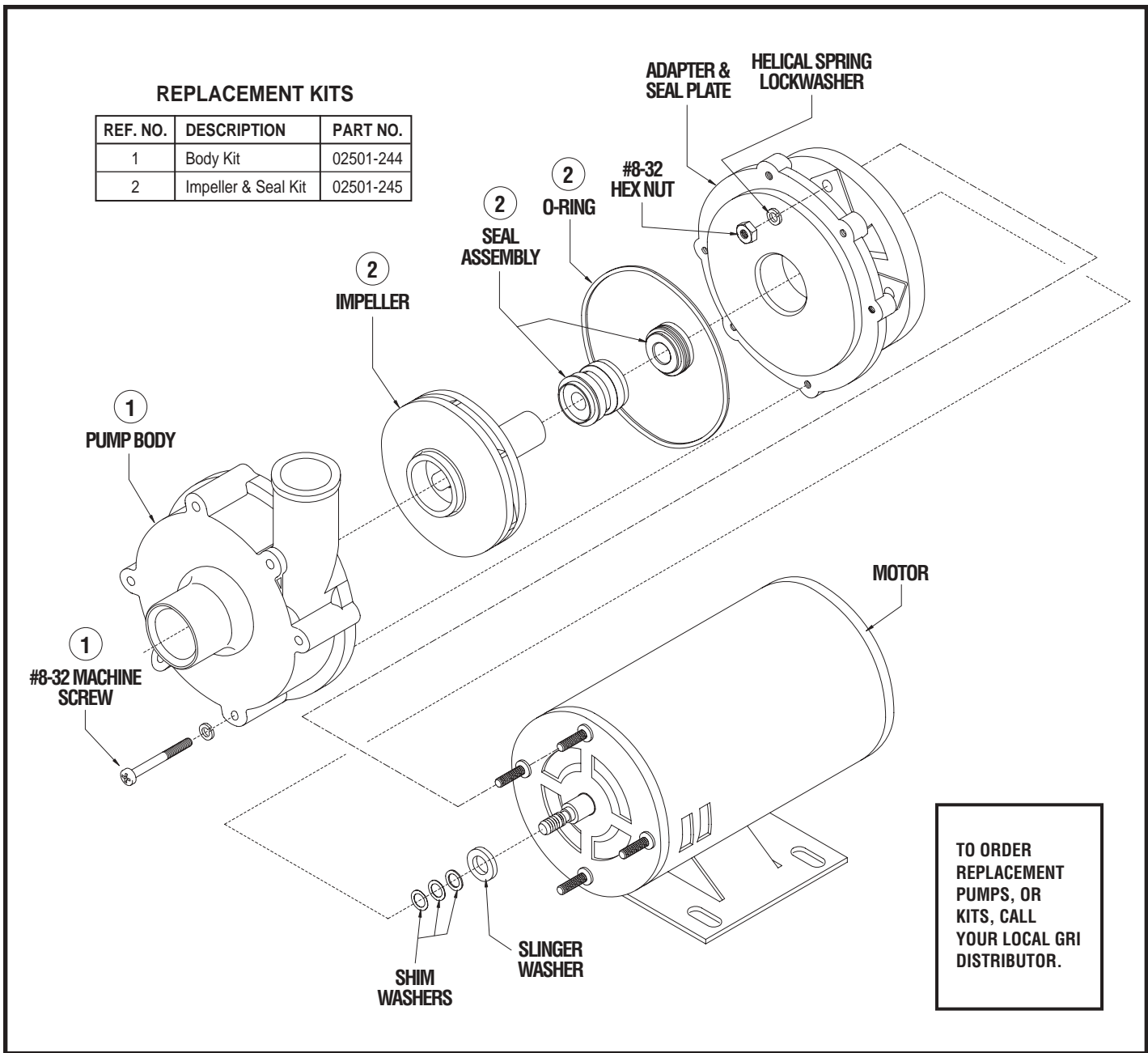

TO ORDER
REPLACEMENT
PUMPS, OR
KITS, CALL
YOUR LOCAL GRI
DISTRIBUTOR.

Registered Trademark Names
NORYL® General Electric Company



DIVISION OF THE GORMAN-RUPP COMPANY
Phone (419) 886-3001 • FAX (419) 886-2338
grisales@gripumps.com • www.gripumps.com