

5600 Series

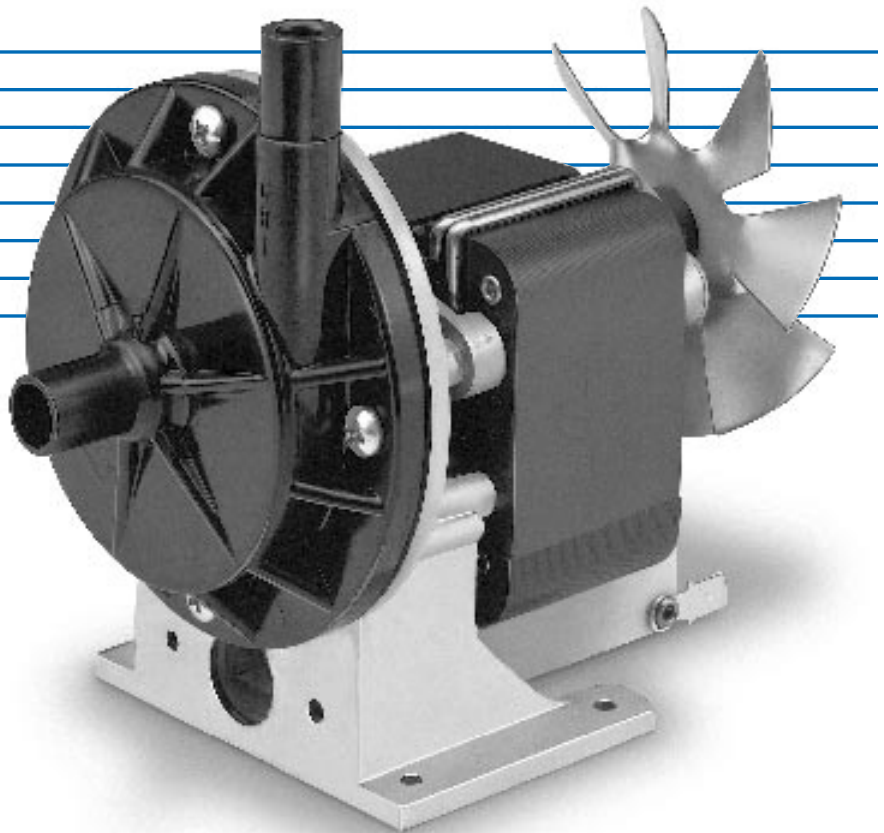

Pump Specifications:

Flow Rates — Range to 3.5 gpm;
maximum head
16.9 feet

Motor — 115V, 50/60 Hz
Shaded pole,
thermally protected

**Fluid
Temperature** — To 220°F (104°C)

Materials in Contact with Solution:

Body — Phenolic
Impeller — Phenolic
Seal — Carbon and
316 Stainless
Steel faces with
Polyethylene
and Nitrile
elastomers

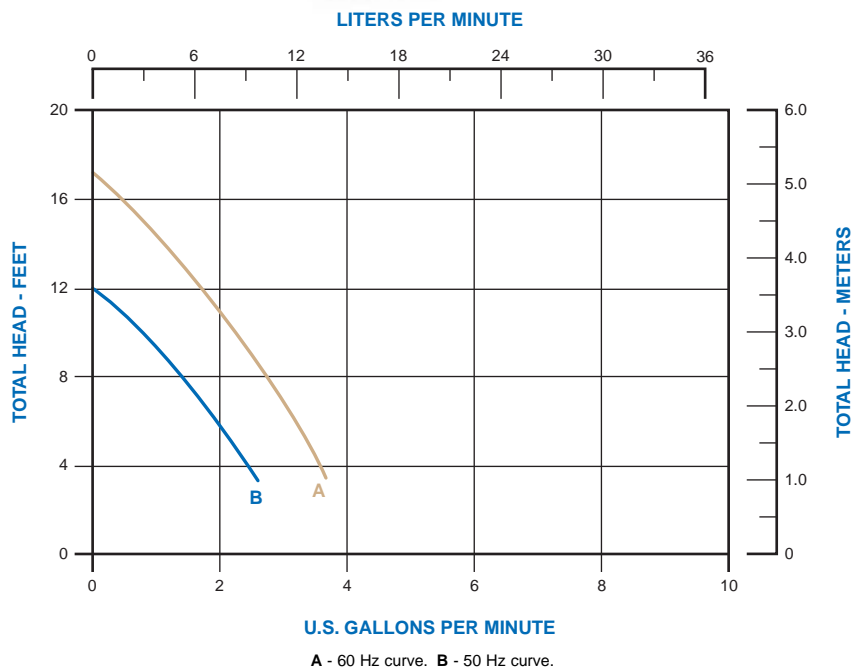

TOTAL HEAD - FEET

TOTAL HEAD - METERS

U.S. GALLONS PER MINUTE

A - 60 Hz curve. B - 50 Hz curve.

MODEL SPECIFICATIONS

Model Number	Series	Seal	Volts	Hz	Amps	Motor Type	Shell	Typical Curve		Approx. Wt.
								50 Hz	60 Hz	
15902-001	5600	Mech	115	50/60	2.4/1.6	SP	Open	B	A	4.5 lbs.
15951-001	Same as 15902-001 except with 6' cord and cover									

CENTRIFUGAL PUMPS - TYPICAL DIMENSIONS

5600 Series Model

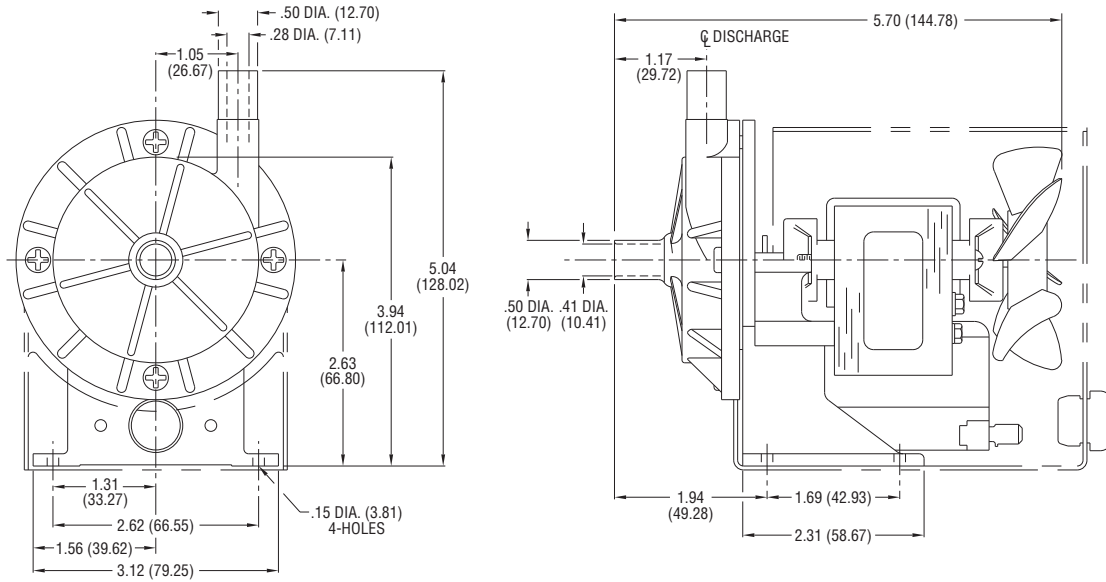

Dimensions in Inches
(Dimensions in Millimeters)

OEM Options

- Impeller** — Stainless Steel
- Seals** —
- Buna N lip seal
 - Carbon vs. 316
Stainless Steel with
Brass, 302 Stainless
Steel and Kel-F® or
Butyl and EPT/
EPDM elastomers
- Motors** —
- 115V, 60 Hz
 - 230V, 50/60 Hz
 - 220/240V, 50 Hz